

TENSOR AB

Copyright TENSOR AB

AHA-200 Pneumatic

The 200 series are wire shears with an extremely low weight, made for cutting wire, spring wire, mesh etc.

The 203 - 206 tools are pneumatic operated with a recommended pressure between 5 to 6 Bar (75-90 psi).

The 200 tools are very easy to handle and operated by a lever on the body, the lever can be rotated round the body.

The standard blade is made of high class forged steel and is available with carbide tip.



DIMENSIONS (mm):

	L	Weight	Cutting capacity		
	mm		kg	Cu	Soft steel*
AHA-203	185	0,63	3,3	2,8	1,4
AHA-204	277	0,94	4,5	3,8	1,8
AHA-205	370	1,5	6	5	-
AHA-206	370	2	7	6	-

* Soft steel ~600 N/mm² Hard steel ~1800N/mm²

Dimension: AHA-203, 204.

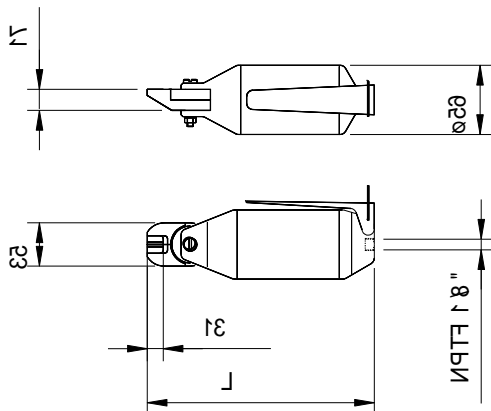

TEN200P

SPECIFICATION:

CUTTER Wire shear AHA-2aa

a=Max dimension:

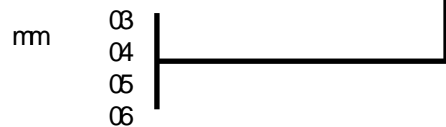

Blade

a=Size: 03, 04=03
05, 06=05

b=Bladetype:

Standard =1
Carbide tip=2

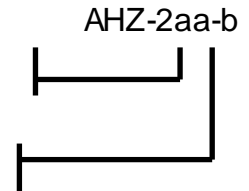

Dimension: AHA-205, 206.

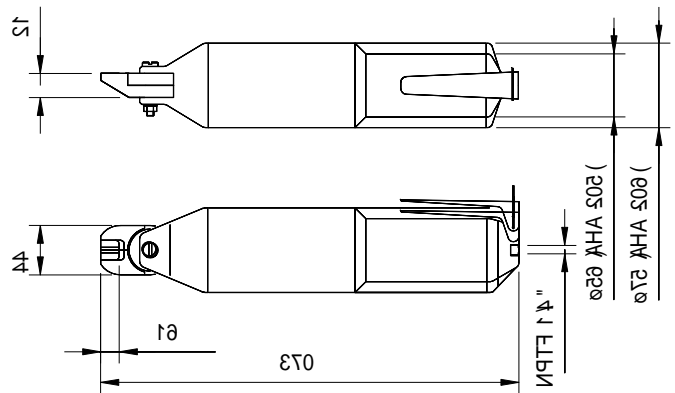

Subject to alteration without previous notice.

TENSOR AB, Vagnmakaregatan 1b, S-415 72, GOTHENBURG, SWEDEN

TELEPHONE + 46 31 790 42 00

E-mail: info@tensor.se

Website: www.tensor.se