

# TENSOR AB

Copyright TENSOR AB

## AHA-300 series

The 300 series are wire shears with an extremely low weight, made for cutting wire, spring wire, mesh, prestressed wire etc

The 300 tools are hydraulic operated with a maximum pressure of 210 Bar or 700 Bar.

The 300 tools is made for single acting hydraulic system

The 300 tools are very easy to handle and operated by electrical switch on the handle.

Recommended powerpack units:

- AHP-2030, electric oil pump
- AHP-2060, electric oil pump
- AHP-7002, electric oil pump
- AHP-8007, electric oil pump
- AHP-8011, electric oil pump

Accessories:

- Hosekit AH-SL
- Extended handle

Different type of blades to suit application  
Foot operated

DIMENSIONS (mm):

	A	B	C	D	E	F	G	H
<b>AHA-312</b>	64	18	48	78	14	255	139	110
AHA-316	91	19	28	110	39	370	200	150
AHA-322	122	30	38	142	56	460	230	175

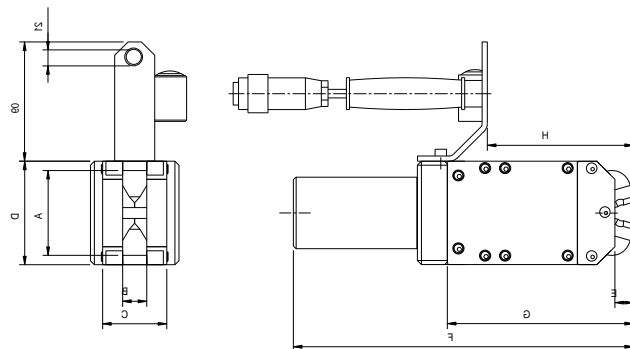

TENAH300



### CUTTING DATA WIRE DIAMETER:

Tensile Strength	AHA-312	AHA-316	AHA-322
N/mm <sup>2</sup>			
700:	10	16	22
1500:	7	11	15

### CUTTING TIME:

Pump unit	AHA-312	AHA-316	AHA-322
AHP-2030	0,8	1,8	-
AHP-2060		0,9	1,8
AHP-7002	3,5	4,0	11,0
AHP-8007	1,0	1,1	
AHP-8011	0,5	0,7	2,1

WEIGHT: 3,1 5,2 15,0 Kg

### SPECIFICATION:

CUTTER Wire shear AHA-3aa-b

a=Max dimension:

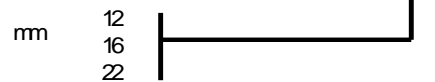

b=hydraulic pressure:

max 210 Bar / 3000 psi =2  
max 700 Bar / 10000 psi =7

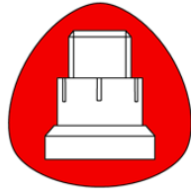

# TENSOR AB

Subject to alteration without previous notice.

Copyright TENSOR AB

---

TENSOR AB, Vagnmakaregatan 1b, S-415 72, GOTHENBURG, SWEDEN

TELEPHONE + 46 31 790 42 00

E-mail: [info@tensor.se](mailto:info@tensor.se)

Website: [www.tensor.se](http://www.tensor.se)